



EVERLIGHT ELECTRONICS CO., LTD.

MODEL NO: 67-22SURSYGC/S530-A2/TR8

Device Number : DSE-672-025 REV. 1.0

TOP LED

ECN : _____ Page: 1/9

Features :

- P-LCC-2package.
- White package.
- Optical indicator.
- Colorless clear window.
- Ideal for backlight and light pipe application.
- Inter reflector.
- Low (2mA) current operation.
- Wide viewing angle.
- Computable with automatic placement equipment.
- Suitable for vapor-phase reflow, Infrared reflow and wave solder processes.
- Available on tape and reel (8mm Tape).

Description :

- The 67-21 series is available in soft-orange, green, blue and yellow, Due to the package design, the LED has wide viewing angle and optimized light coupling by inter reflector, this feature makes the SMT TOP LED ideal for light pipe application, The low current requirement makes this device ideal for portable equipment or any other application where power is at a premium.

Applications :

- Automotive: backlight in dashboards and switches
- Telecommunication: indicator and backlight in telephone and fax.
- Indicator and backlight for audio and video equipment.
- Indicator and backlight in office and family equipment.
- Flat backlight for LCD's, switches and symbols.
- Light pipe application.
- General use.

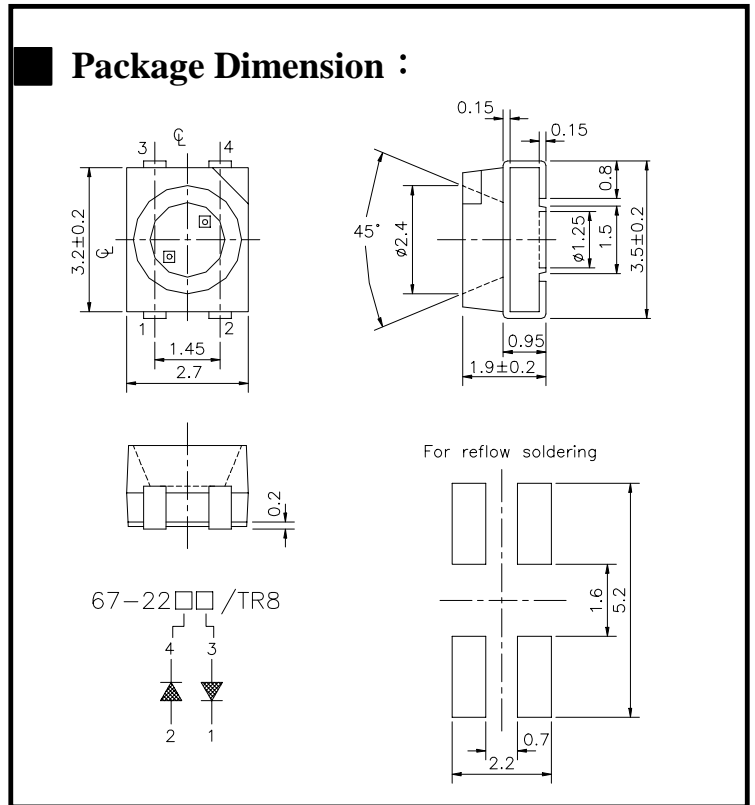

Notes:

Tolerances Unless Dimension $\pm 0.1\text{mm}$
 Angle $\pm 0.5^\circ$
 Unit = mm

PART NO	CHIP		Lens Color
	Material	Emitted Color	
67-22SURSYGC/S530-A2/TR8	AlGaInP	Hyper Red	Water Clear
	AlGaInP	Super Yellow Green	

Office: NO. 25, Lane 76, Sec.3, Chung Yang Rd., Tucheng 236, Taipei, Taiwan, R.O.C.

TEL: 886-2-2267-2000, 2267-9936

FAX: 886-2-2267-6244, 2267-6189, 2267-6306

<http://www.everlight.com>



MODEL NO: 67-22SURSYGC/S530-A2/TR8

Device Number : DSE-672-025 REV. 1.0

TOP LED

ECN : Page: 2/9

■ Package Dimension :

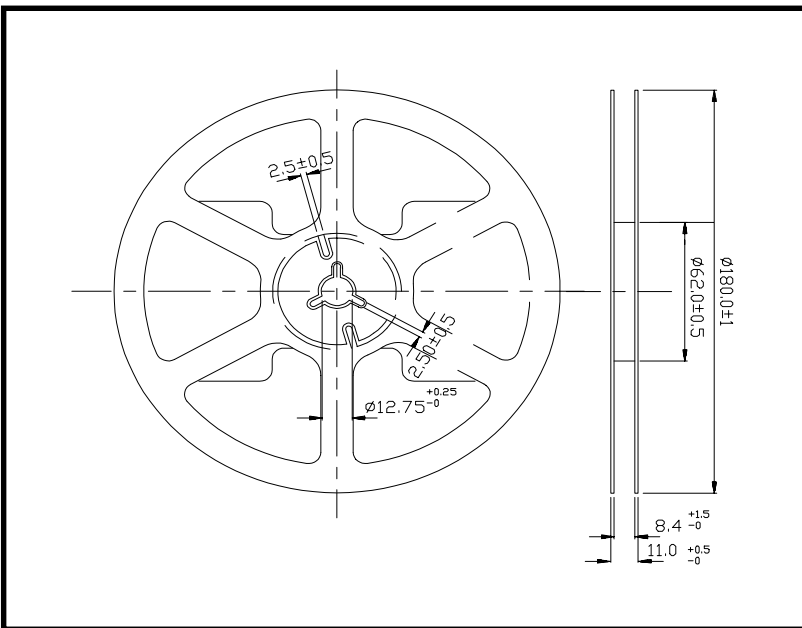

■ Loaded quantity per reel 2000 PCS/reel :

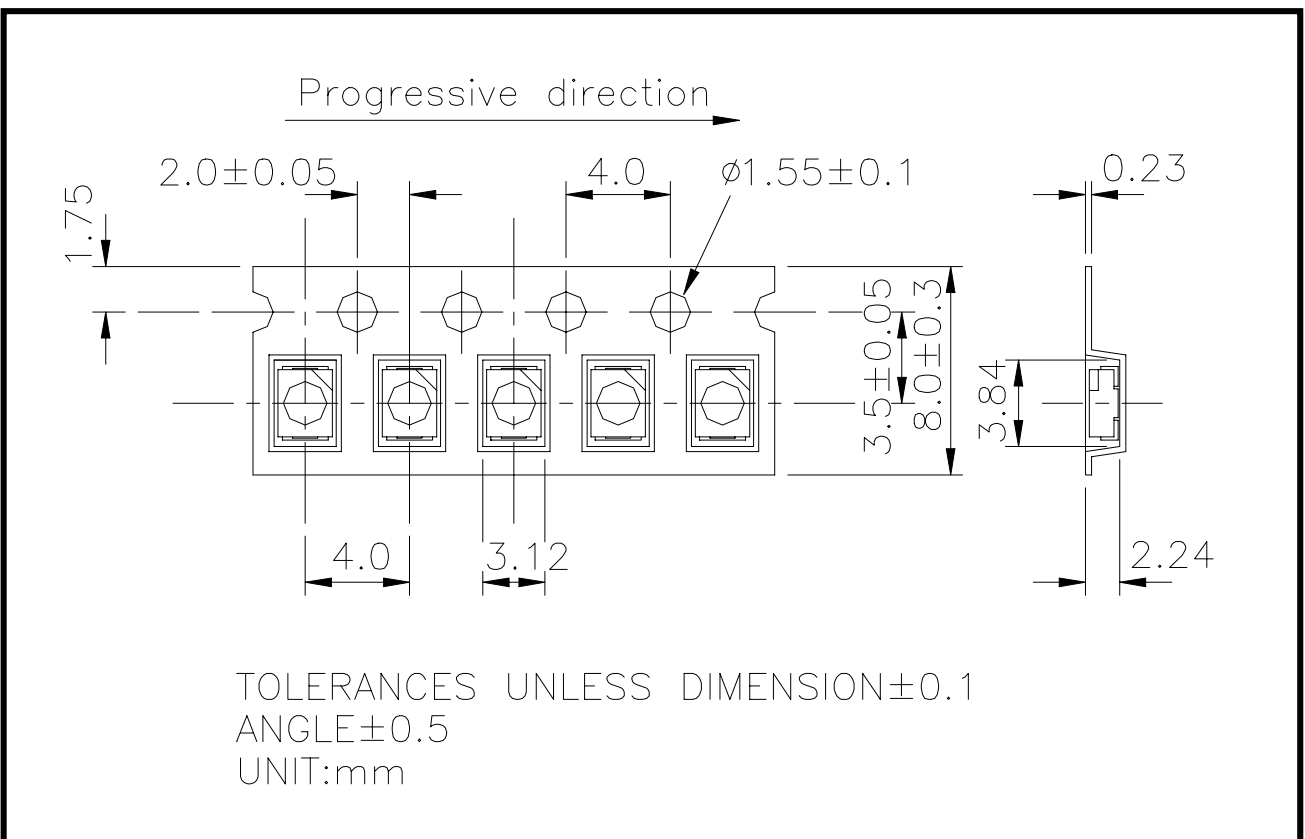



MODEL NO: 67-22SURSYGC/S530-A2/TR8 Device Number : DSE-672-025 REV. 1.0

TOP LED

ECN : _____ Page: 3/9

■ Absolute Maximum Ratings at Ta = 25°C (SUR)

Parameter	Symbol	Rating	Unit
Reverse Voltage	Vr	5	V
Forward Current	If	25	mA
Operating Temperature	Topr	-40 ~ +85	°C
Storage Temperature	Tstg	-40 ~ +90	°C
Soldering Temperature	Tsol	245 (for 5 second)	°C
Electrostatic Discharge	ESD	2000	V
Power Dissipation	Pd	60	MW
Peak Forward Current(Duty 1/10 @ 1KHZ)	If(Peak)	160	MA

■ Electronic Optical Characteristics : (SUR)

Parameter	Symbol	Min.	Typ.	Max.	Unit	Condition
Luminous intensity	Iv	-----	4	-----	mcd	If=2mA
		24	59	-----	mcd	If=20mA
Viewing Angle	2θ 1/2	-----	120	-----	deg	If=20mA
Peak Wavelength	λp	-----	632	-----	nm	If=20mA
Dominant Wavelength	λd	-----	624	-----	nm	If=20mA
Spectrum Radiation Bandwidth	Δλ	-----	20	-----	nm	If=20mA
Forward Voltage	Vf	-----	2.0	2.4	V	If=20mA
Reverse Current	Ir	-----	-----	10	μA	Vr=5V



MODEL NO: 67-22SURSYGC/S530-A2/TR8 Device Number : DSE-672-025 REV. 1.0

TOP LED

ECN : _____ Page: 4/9

■ Absolute Maximum Ratings at Ta = 25°C (SYG)

Parameter	Symbol	Rating	Unit
Reverse Voltage	Vr	5	V
Forward Current	If	25	mA
Operating Temperature	Topr	-40 ~ +85	°C
Storage Temperature	Tstg	-40 ~ +90	°C
Soldering Temperature	Tsol	260 (for 5 second)	°C
Electrostatic Discharge	ESD	2000	V
Power Dissipation	Pd	60	mW
Peak Forward Current(Duty 1/10 @ 1KHZ)	If(Peak)	160	mA

■ Electronic Optical Characteristics (SYG)

Parameter	Symbol	Min.	Typ.	Max.	Unit	Condition
Luminous intensity	Iv	-----	1	-----	mcd	If=2mA
		16	24	-----	mcd	If=20mA
Viewing Angle	2θ 1/2	-----	120	-----	deg	If=20mA
Peak Wavelength	λp	-----	575	-----	nm	If=20mA
Dominant Wavelength	λd	-----	573	-----	nm	If=20mA
Spectrum Radiation Bandwidth	Δλ	-----	20	-----	nm	If=20mA
Forward Voltage	Vf	-----	2.0	2.4	V	If=20mA
Reverse Current	Ir	-----	-----	10	μA	Vr=5V



MODEL NO: 67-22SURSYGC/S530-A2/TR8 Device Number : DSE-672-025 REV. 1.0
TOP LED

ECN : _____ Page: 5/9

■ Reliability Test Item And Condition

NO	Item	Test Conditions	Test Hours/Cycle	Sample Size	Ac/Re
1	Solder Heat	TEMP : 260°C ± 5 °C	5 SEC	76 Pcs	0/1
2	Temperature Cycle	H : +85°C 30min ∫ 5 min L : -55°C 30min	50 CYCLE	76 Pcs	0/1
3	Thermal Shock	H : +100°C 5min ∫ 10 sec L : -10°C 5min	50 CYCLE	76 Pcs	0/1
4	High Temperature Storage	TEMP : 100°C	1000 HRS	76 Pcs	0/1
5	Low Temperature Storage	TEMP : -55°C	1000 HRS	76 Pcs	0/1
6	DC Operating Life	If = 20 mA	1000 HRS	76 Pcs	0/1
7	High Temperature / High Humidity	85°C /85% RH	1000 HRS	76 Pcs	0/1

Products are evaluated according to the above standard reliability criteria.



MODEL NO: 67-22SURSYGC/S530-A2/TR8
TOP LED

Device Number : DSE-672-025 REV. 1.0

ECN : Page: 6/9

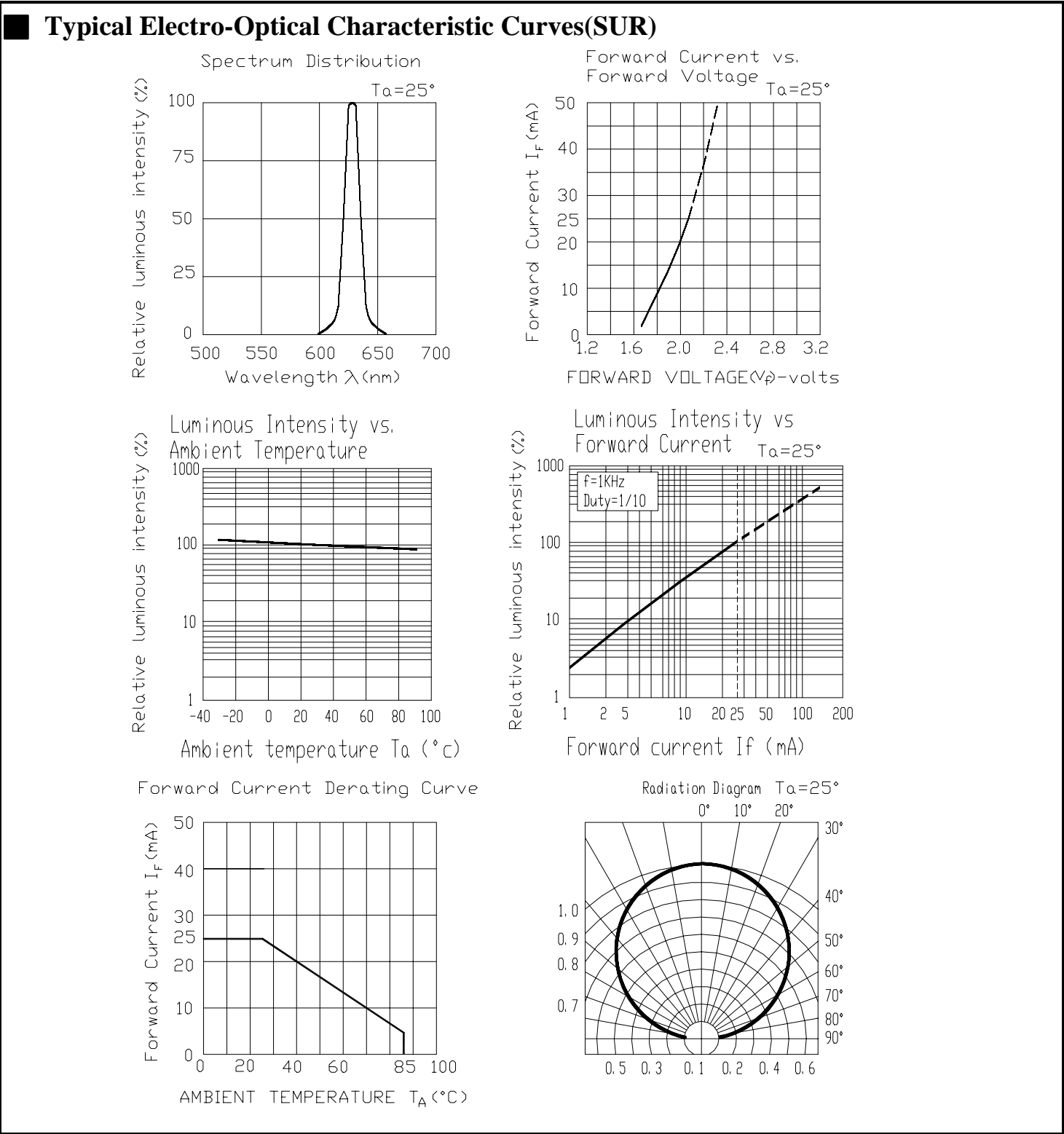



MODEL NO: 67-22SURSYGC/S530-A2/TR8
TOP LED

Device Number : DSE-672-025 REV. 1.0

ECN : Page: 7/9

Typical Electro-Optical Characteristic Curves(SYG)

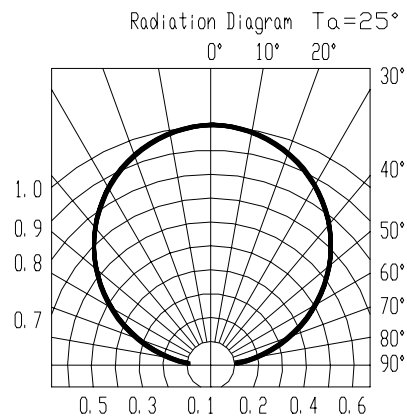
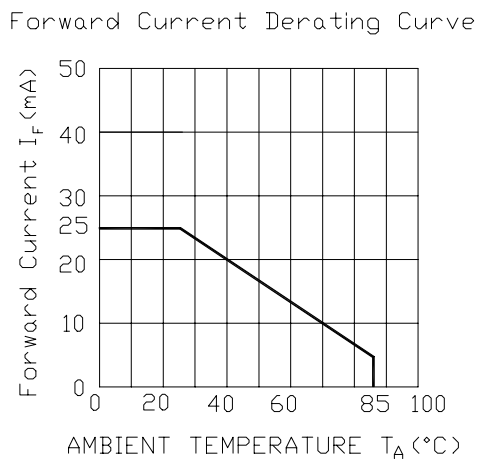
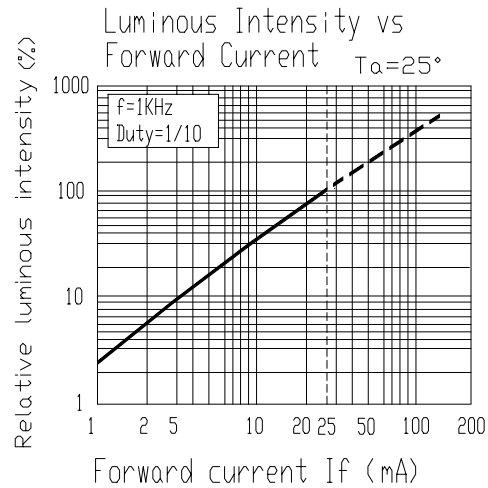
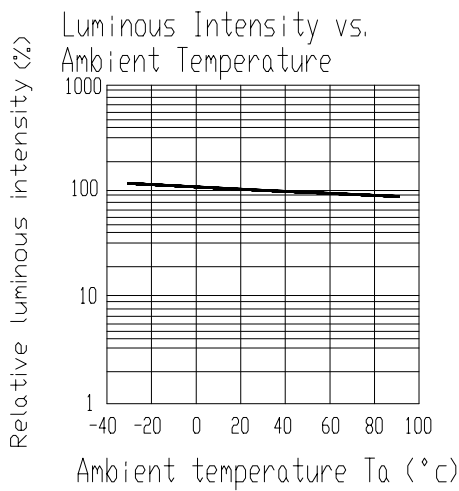
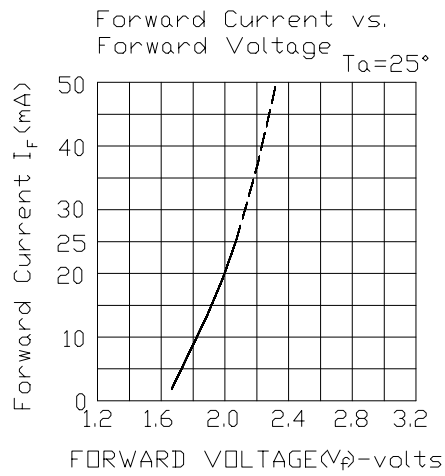
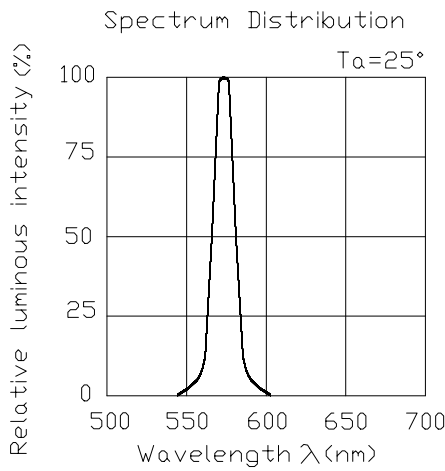



MODEL NO: 67-22SURSYGC/S530-A2/TR8 Device Number : DSE-672-025 REV. 1.0

TOP LED

ECN : _____ Page: 8/9

■ **Soldering heat reliability (DIP)**

Please refer to the following figure :

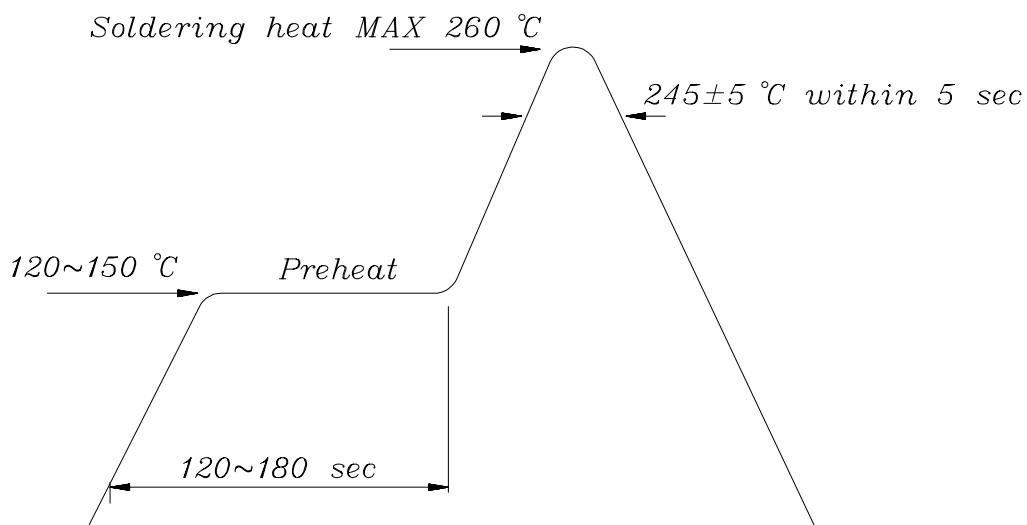

■ **Soldering Iron**

Basic spec is ≤ 5 sec when 245°C . If temperature is higher, time should be shorter ($+10^{\circ}\text{C} \rightarrow -1\text{sec}$). Power dissipation of Iron should be smaller than 15 W , and temperature should be controllable. Surface temperature of the device should be under 230°C .

■ **Rework**

1. Customer must finish rework within 5 sec under 245°C .
2. The head of iron can not touch copper foil.
3. Twin-head type is preferred.

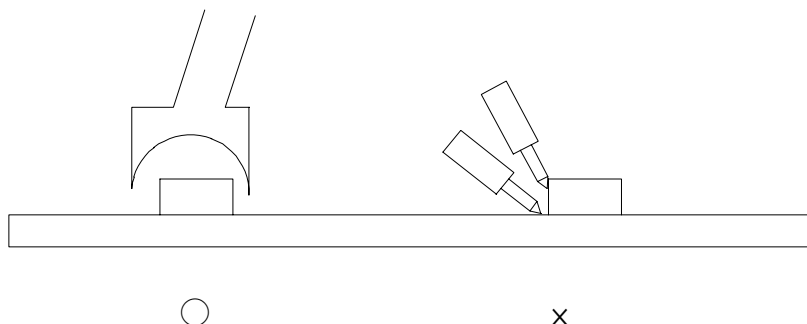



MODEL NO: 67-22SURSYGC/S530-A2/TR8

Device Number : DSE-672-025 REV. 1.0

TOP LED

ECN : Page: 9/9

■ Reflow Temp / Time :

