

Technical Data Sheet**Bi-Color (Multi-color) Top Views LEDs****67-22/R6BHC-B07/2T****Features**

- P-LCC-4 package.
- White package.
- Optical indicator.
- Colorless clear window.
- Ideal for backlight and light pipe application.
- Inter reflector.
- Wide viewing angle.
- Suitable for vapor-phase reflow, Infrared reflow and wave solder processes.
- Computable with automatic placement equipment.
- Available on tape and reel (8mm Tape).
- Pb-free.
- The product itself will remain within RoHS compliant version

**Descriptions**

- The 67-22 series is available in soft orange, green, blue and yellow. Due to the package design, the LED has wide viewing angle and optimized light coupling by inter reflector. This feature makes ideal for light pipe application. The low current requirement makes this device ideal for portable equipment or any other application where power is at a premium.

Applications

- Telecommunication: indicator and backlighting in telephone and fax.
- Flat backlight for LCD's, switches and symbols.
- Light pipe application.
- General use.

Device Selection Guide

Chip			Lens Color
Type	Material	Emitted Color	
R6	AlGaInP	Brilliant Red	Water Clear
BH	InGaN	Blue	

Package Dimensions

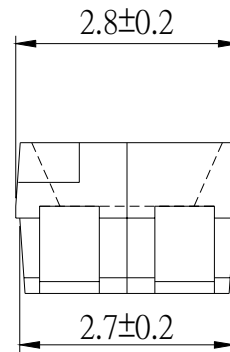
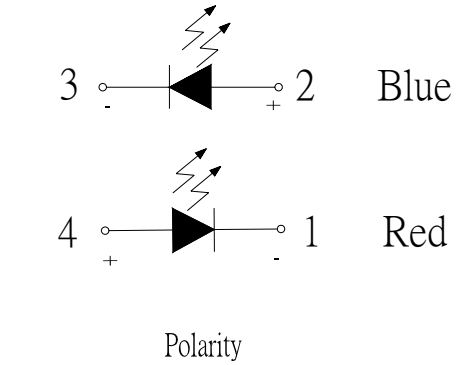
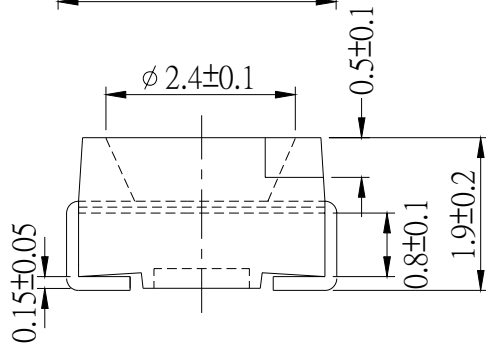
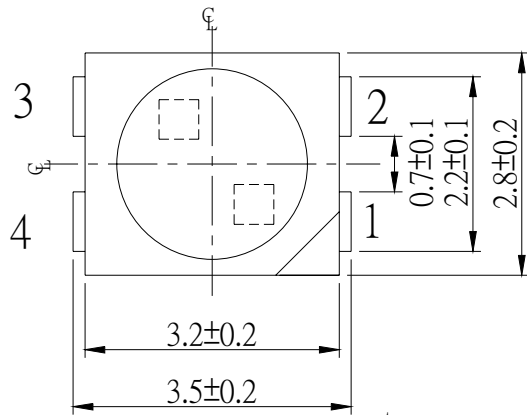

For reflow soldering(propose)

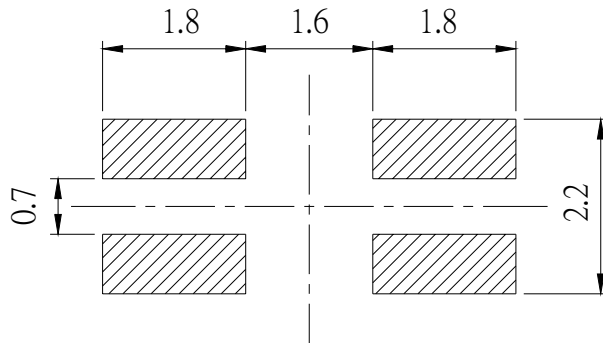
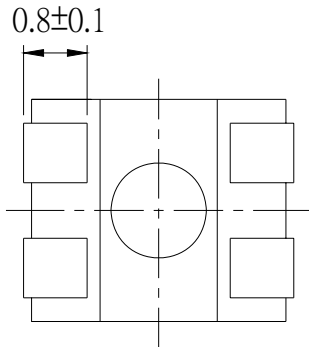

Note: The tolerances unless mentioned is ±0.1mm;Unit = mm

67-22/R6BHC-B07/2T
Absolute Maximum Ratings (Ta=25°C)

Parameter	Symbol	Rating	Unit
Reverse Voltage	V _R	5	V
Forward Current	I _F	R6	50
		BH	25
Operating Temperature	T _{opr}	-40 ~ +85	°C
Storage Temperature	T _{stg}	-40~ +100	°C
Electrostatic Discharge(HBM)	ESD	R6	2000
		BH	150
Power Dissipation	P _d	R6	120
		BH	110
Peak Forward Current(Duty 1/10 @ 1KHz)	I _{FP}	R6	100
		BH	100
Soldering Temperature	T _{sol}	Reflow Soldering : 260 °C for 10 sec. Hand Soldering : 350 °C for 3 sec.	

Electro-Optical Characteristics (Ta=25°C)

Parameter	Symbol	Min.	Typ.	Max.	Unit	Condition	
Luminous Intensity	I _v	R6	90	-----	225	mcd	
		BH	90	-----	225		
Viewing Angle	2θ 1/2	-----	120	-----	deg	I _F =20mA	
Peak Wavelength	λ _p	R6	-----	632	-----		nm
		BH	-----	468	-----		
Dominant Wavelength	λ _d	R6	621	-----	631		nm
		BH	466.5	-----	471.5		
Spectrum Radiation Bandwidth	Δλ	R6	-----	20	-----		nm
		BH	-----	35	-----		
Forward Voltage	V _F	R6	1.75	-----	2.35	V	
		BH	2.9	-----	3.7		
Reverse Current	I _R	-----	-----	10	μA	V _R =5V	

- Notes:**
- 1.Tolerance of Luminous Intensity ±10%
 - 2.Tolerance of Dominant Wavelength ±1nm
 - 3.Tolerance of Forward Voltage ±0.1V

67-22/R6BHC-B07/2T

Bin Range Of Luminous Intensity

Chip	Bin Code	Min.	Max.	Unit	Condition
R6	Q2	90.0	112	mcd	I _F =20mA
	R1	112	140		
	R2	140	180		
	S1	180	225		
BH	Q2	90.0	112		
	R1	112	140		
	R2	140	180		
	S1	180	225		

Bin Range Of Dominant Wavelength

Chip	Bin Code	Min.	Max.	Unit	Condition
R6	FF1	621	626	nm	I _F =20mA
	FF2	626	631		

Bin Range Of Forward Voltage

Chip	Bin Code	Min.	Max.	Unit	Condition
R6	0	1.75	1.95	V	I _F =20mA
	1	1.95	2.15		
	2	2.15	2.35		
BH	11	2.90	3.10		
	12	3.10	3.30		
	13	3.30	3.50		
	14	3.50	3.70		

Notes:

- 1.Tolerance of Luminous Intensity $\pm 10\%$
- 2.Tolerance of Dominant Wavelength $\pm 1\text{nm}$
- 3.Tolerance of Forward Voltage $\pm 0.1\text{V}$

Typical Electro-Optical Characteristics Curves(R6)

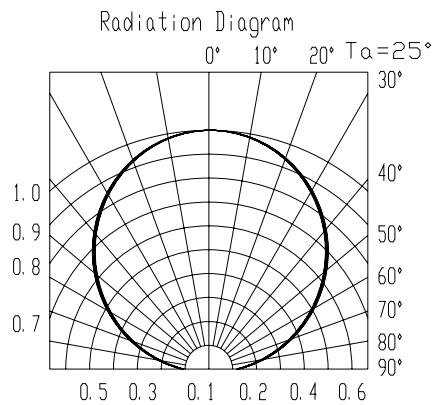
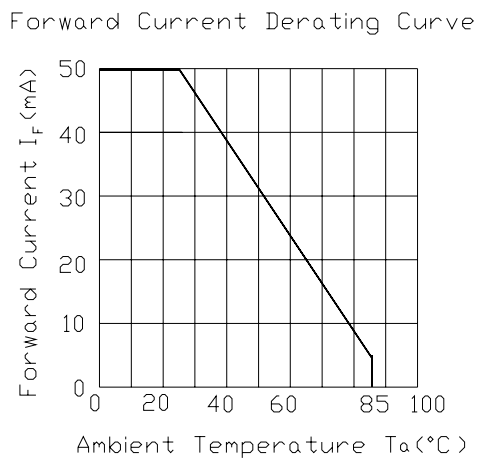
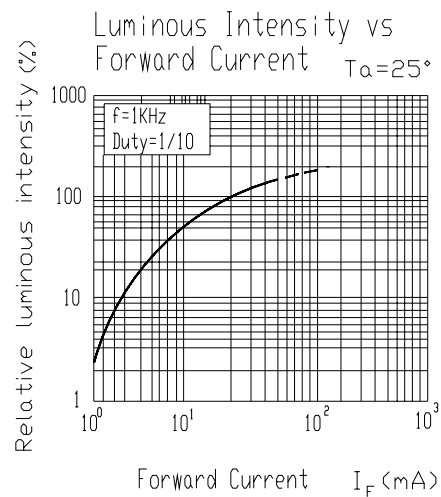
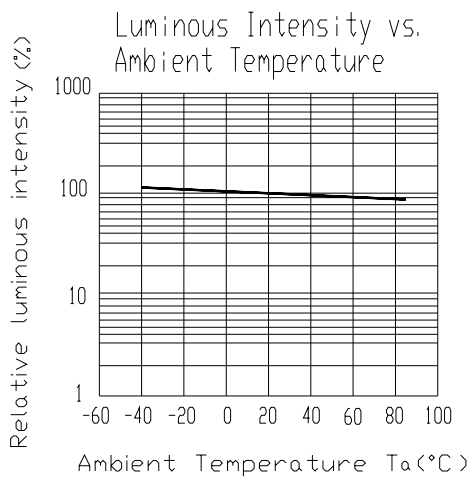
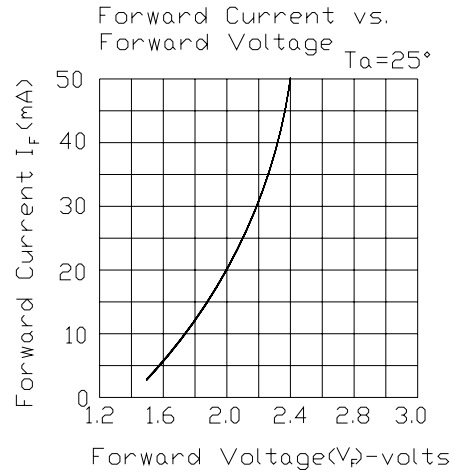
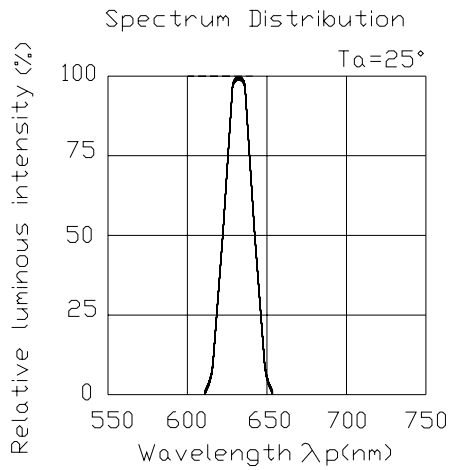

Typical Electro-Optical Characteristics Curves(BH)

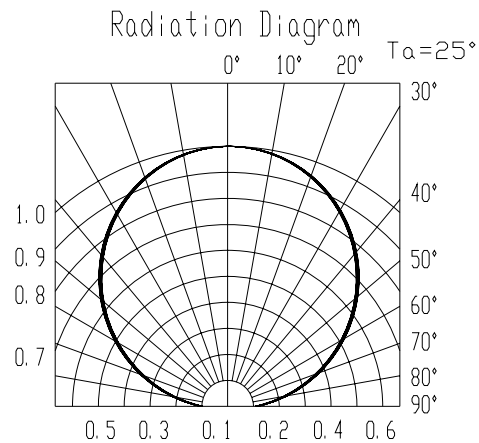
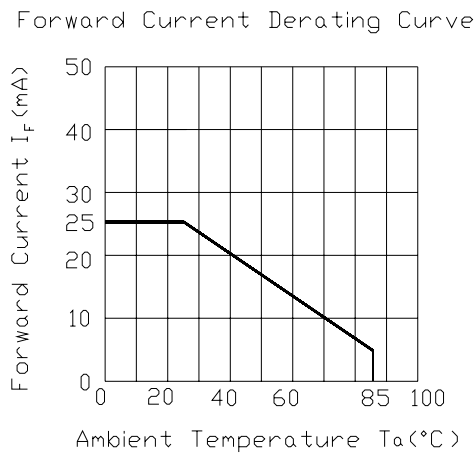
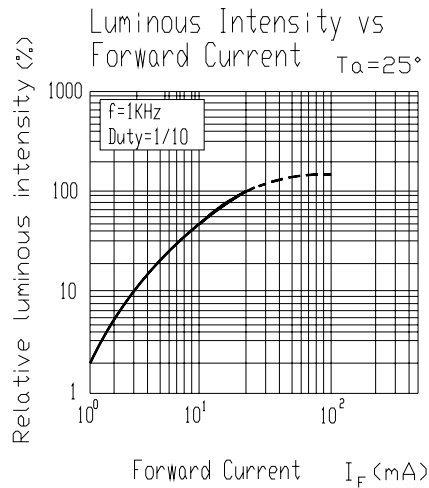
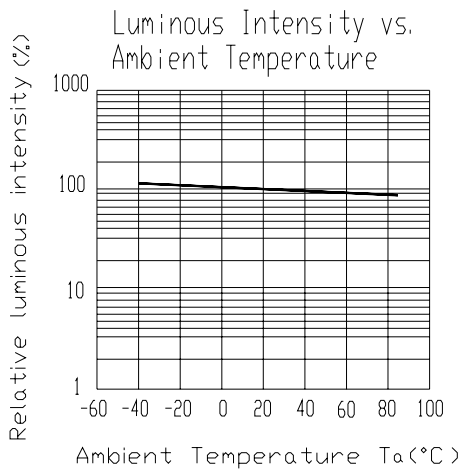
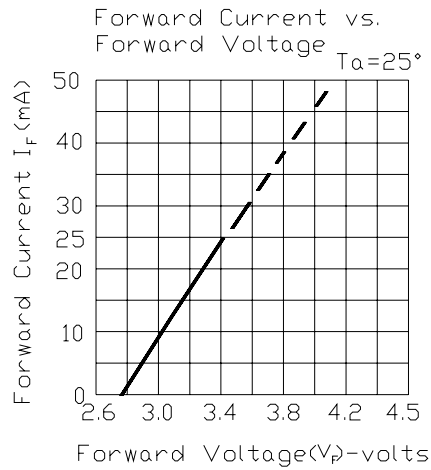
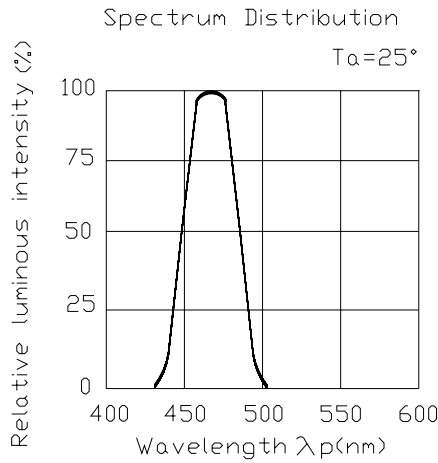

67-22/R6BHC-B07/2T

Label explanation

CAT: Luminous Intensity Rank

HUE: Dom. Wavelength Rank

REF: Forward Voltage Rank

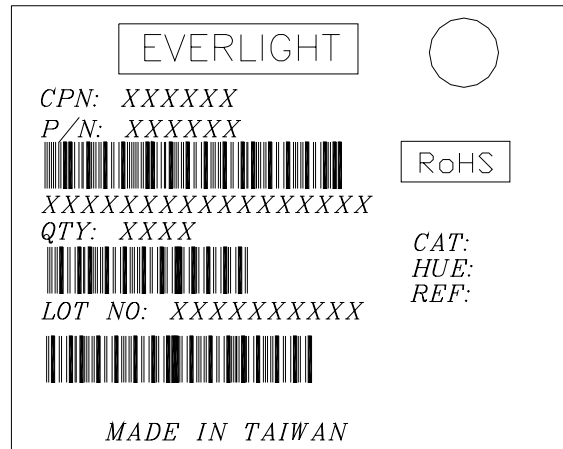

Reel Dimensions

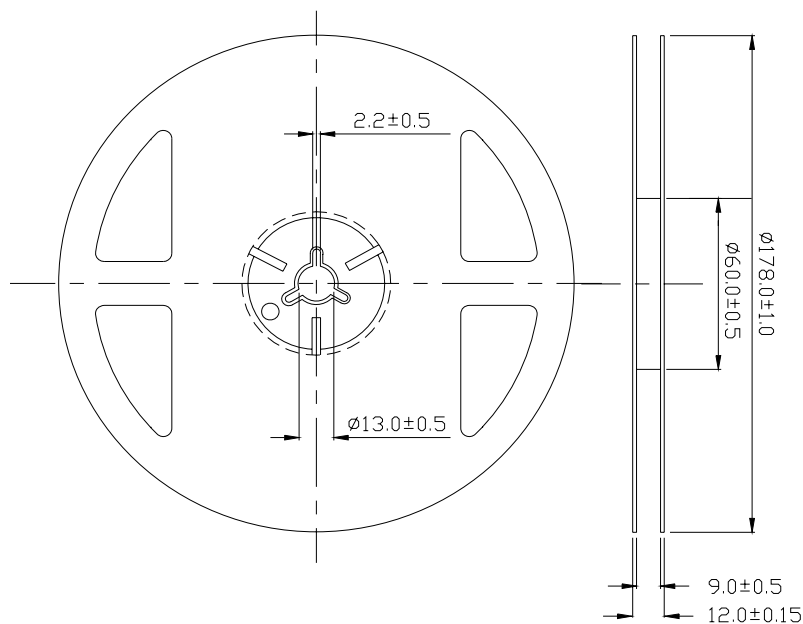

Note: The tolerances unless mentioned is $\pm 0.1\text{mm}$,Unit = mm

Carrier Tape Dimensions: Loaded quantity 2000 PCS per reel.

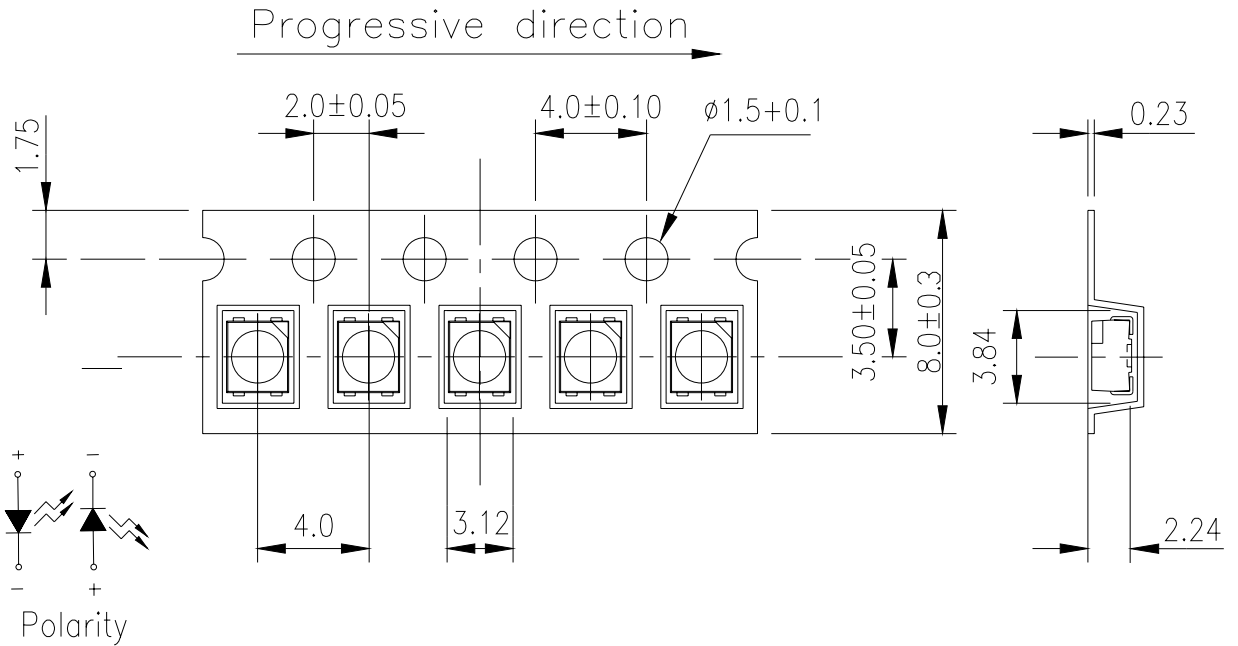

NOTE :TOLERANCES UNLESS DIMENSION ±0.1 mm

UNIT: mm

Moisture Resistant Packaging

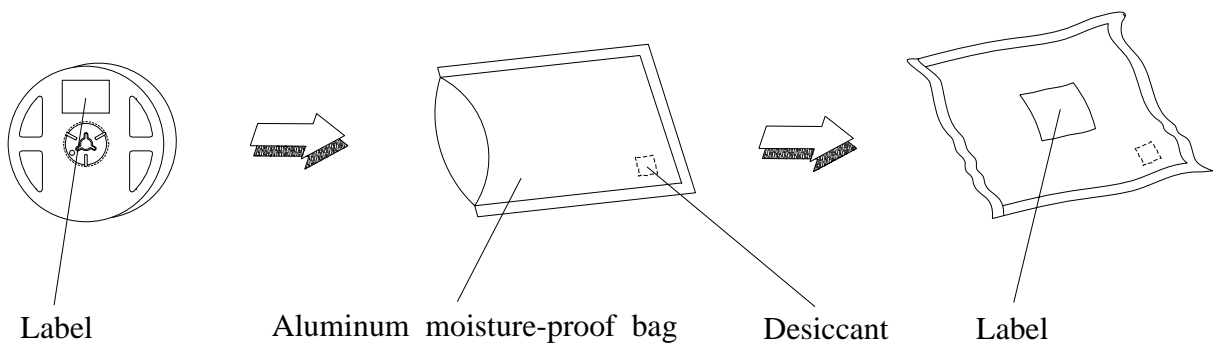

67-22/R6BHC-B07/2T
Reliability Test Items And Conditions

The reliability of products shall be satisfied with items listed below.

Confidence level : 90%

LTPD : 10%

No.	Items	Test Condition	Test Hours/Cycles	Sample Size	Ac/Re
1	Reflow Soldering	Temp. : 260°C±5°C Min. 5sec.	6 min	22 PCS.	0/1
2	Temperature Cycle	H : +100°C 15min ∫ 5 min L : -40°C 15min	300 Cycles	22 PCS.	0/1
3	Thermal Shock	H : +100°C 5min ∫ 10 sec L : -10°C 5min	300 Cycles	22 PCS.	0/1
4	High Temperature Storage	Temp. : 100°C	1000 Hrs.	22 PCS.	0/1
5	Low Temperature Storage	Temp. : -40°C	1000 Hrs.	22 PCS.	0/1
6	DC Operating Life	I _F = 20 mA/ 25°C	1000 Hrs.	22 PCS.	0/1
7	High Temperature / High Humidity	85°C/ 85%RH	1000 Hrs.	22 PCS.	0/1

Precautions For Use

1. Over-current-proof

Customer must apply resistors for protection , otherwise slight voltage shift will cause big current change (Burn out will happen).

2. Storage

2.1 Do not open moisture proof bag before the products are ready to use.

2.2 Before opening the package, the LEDs should be kept at 30°C or less and 90%RH or less.

2.3 The LEDs should be used within a year.

2.4 After opening the package, the LEDs should be kept at 30°C or less and 70%RH or less.

2.5 The LEDs should be used within 168 hours (7 days) after opening the package.

2.6 If the moisture absorbent material (silica gel) has faded away or the LEDs have exceeded the storage time, baking treatment should be performed using the following conditions.

Baking treatment : 60±5°C for 24 hours.

3. Soldering Condition

3.1 Pb-free solder temperature profile

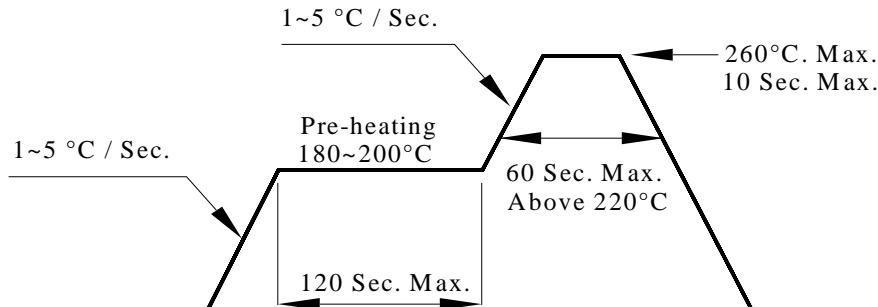

3.2 Reflow soldering should not be done more than two times.

3.3 When soldering, do not put stress on the LEDs during heating.

3.4 After soldering, do not warp the circuit board.

4.Soldering Iron

Each terminal is to go to the tip of soldering iron temperature less than 350°C for 3 seconds within once in less than the soldering iron capacity 25W. Leave two seconds and more intervals, and do soldering of each terminal. Be careful because the damage of the product is often started at the time of the hand solder.

5.Repairing

Repair should not be done after the LEDs have been soldered. When repairing is unavoidable, a double-head soldering iron should be used (as below figure). It should be confirmed beforehand whether the characteristics of the LEDs will or will not be damaged by repairing.

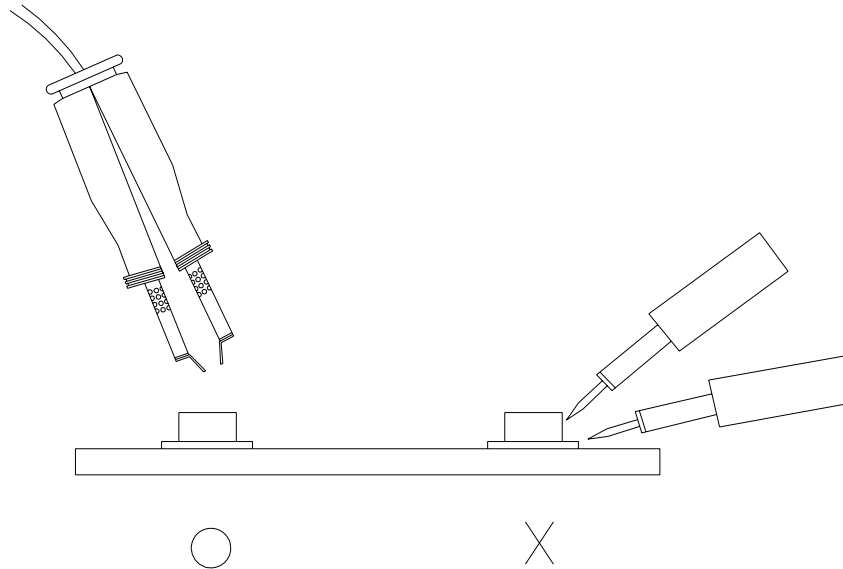

EVERLIGHT ELECTRONICS CO., LTD.
Office: No 25, Lane 76, Sec 3, Chung Yang Rd,
Tucheng, Taipei 236, Taiwan, R.O.C

Tel: 886-2-2267-2000, 2267-9936
Fax: 886-2267-6244, 2267-6189, 2267-6306
<http://www.everlight.com>